

**Rectangular VAV and CAV air volume control units
NK / NL series**

Description	Page
Type designation	1
Technical data	
- General	2
- Specification	3
- Installation instructions	3
Model overview / dimensions	4 - 5
Sound data NKOAOOB / NLOAOOB	6 - 7
Sound data NKODOOB / NLODOOB	8 - 9

Rectangular VAV and CAV air volume control units

Type designation
Single wall (NK.....)
Double wall (NL.....)

Composition type designation:

N - K - O - D - O - O - B

N Position 1: **Product group**

N = air volume control units

K Position 2: **Function**

O = not applicable
K = single wall, rectangular VAV unit, flanged type
L = double wall, rectangular VAV unit, flanged type
1 = non standard, specify separately

O Position 3: **Controls (manufacturer)**

O = without controls
For controls, contact our sales staff

D Position 4: **Outlet and sound attenuator**

O = not applicable
A = rectangular outlet
D = rectangular outlet with sound attenuator
N = rectangular outlet with plenum for electric reheat coil
R = rectangular outlet with sound attenuator and with plenum for electheat coil
1 = non standard, specify separately

O Position 5: **Reheat**

O = not applicable
E = 1-stage 230VAC/1-phase electric reheat coil
F = 2-stage 230VAC/1-phase electric reheat coil
G = 3-stage 230VAC/1-phase electric reheat coil
H = 1-stage 400VAC/3-phase electric reheat coil
J = 2-stage 400VAC/3-phase electric reheat coil
1 = non standard, specify separately

O Position 6: **Controls (type & function)**

O = without controls
For controls, contact our sales staff

B Position 7: **Sensor**

O = not applicable
B = Flo-Cross®, 2 x 12 point averaging and signal amplifying air flow sensor (standard)
1 = non standard, specify separately

Ordering example:

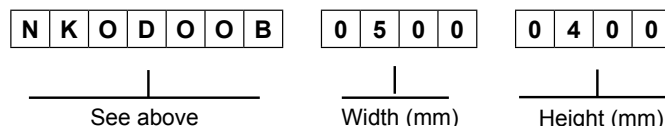

Ordering information:

Standard units:

- quantity of units
- complete 7 digit code
- unit size or model
- air volume setting (V_{max} , V_{min} etc)
- control handing (standard right side)
- If applicable, electric reheat coil capacity

Non standard units:

- For non standard units a full description and/or drawing are requested.

Rectangular VAV and CAV air volume control units

Technical data
Single wall (NK.....)
Double wall (NL.....)

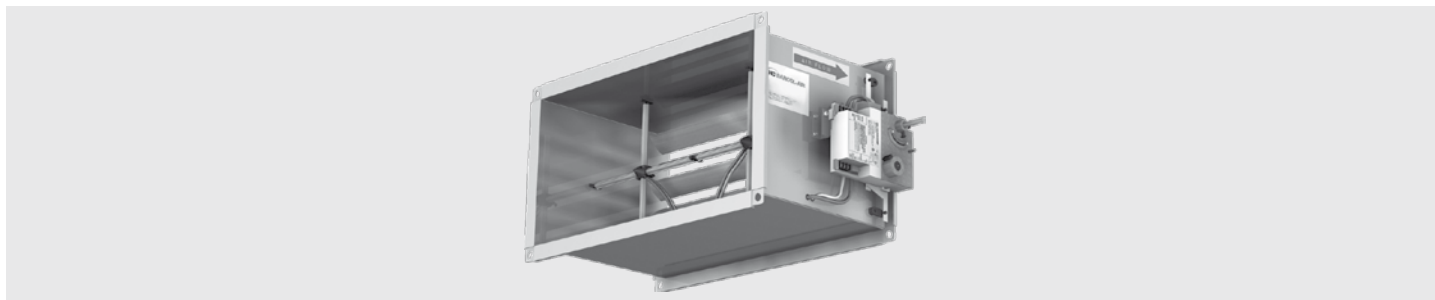

Application

Types NK and NL are rectangular pressure-independent VAV and CAV air volume control terminals.

The units are designed particularly for systems with larger air volumes and duct sizes and for the accurate measurement and control of air volumes courtesy of the patented airflow sensor type Flo-Cross®.

In CAV application, the unit maintains the required constant airflow independent to the inlet static pressure.

In VAV application, the unit controls the air volume to the room, depending on the cooling load required thus saving energy consumption in both cooling and heating applications.

The VAV or CAV units can be used either for supply or return air applications in new or refurbishment projects.

The units do have a single wall (NK) or double wall (NL) construction and can optionally be supplied with an additional sound attenuator and a plenum with built-in electric reheat coil.

Features:

- Pressure independent control functions.
- Compact design.
- Volume control range 100% down to 10%
- Low pressure loss over the unit.
- Single or double wall construction.
- Factory fitted additional attenuator and/or plenum with built-in electric reheat coil.
- Multi-leaf damper blade; full shut-off optional.
- Low noise production.
- Suitable for large air volumes.
- Suitable for all control functions (VAV, CAV, shut-off, etc.) to maximise system energy savings.
- Flo-Cross® 2x12 points averaging and signal amplifying airflow sensor, better than 2,5% accuracy even with irregular duct approach.
- Maintenance free.

Technical information

Casing:

Single or double wall, air-tight construction made of galvanized sheet steel; casing leakage rate to Class II VDI 3803 / DIN 24 194. 30 mm flange connections at the in- and outlet. In case of double wall construction 25 mm insulation material is used completely enclosed by the double wall construction.

Insulation:

The unit is supplied with 25 mm thermal and acoustical insulation (30 kg/m³) complying to: NFPA90A and 90B surface burning characteristics, BS476 part 6 and 7 fire propagation and class 0 surface spread of flame.

Damper:

Damper blades: aluminium, aerofoil 50-mm opposed blade construction with external linkage.

Blades are optional provided with neoprene gasket for full shut-off function.

Damper shaft: steel, ø10 mm rotating in self lubricating Nylon bearings.

Flo-Cross®:

Extruded aluminium construction with nylon core + feet.

Sound attenuator:

Constructed from galvanized sheet steel, internal acoustic insulation tested to Class 'O' fire regulation, erosion proof up to 30 m/s. Special version insulation for hospital application on request.

.

Reheat coil:

Choice of electric reheat coil 230VAC/1-phase or 400VAC/3-phase.

Coils are fitted in plenum made of galvanised sheet steel with 13mm internal isolation, type fireflex S305 (30 kg/m³). More detailed technical information can be found in part NO of the catalogue.

Controls:

Suitable for use with pneumatic, analogue electronic or DDC controllers. Controls can be factory fitted, wired and calibrated. Controls enclosure (galvanised sheet steel) can be provided optionally.

Delivery format

Delivery format:

- The VAV or CAV unit will be supplied as a single mounting assembly. Optional ordered distribution plenum, reheat coil and/or controls are factory fitted, wired and calibrated. The on site delivered unit is ready to be installed and commissioned.
- Controls location and hot water or electric connections are as a standard fitted on the right hand side of the unit when looking in the direction of the airflow.
- On request, the unit can be delivered with connections on the left hand side.
- When units are ordered with controls, these will be factory fitted, wired and calibrated upon request.
- When units are ordered with 'free-issue' controls by others, wiring diagrams and mounting instructions must be provided.

Rectangular VAV and CAV air volume control units

Technical data
Single wall (NK.....)
Double wall (NL.....)



Specify as:

Example:

Supply and install, variable air volume units, double-wall construction with sound attenuator with rectangular outlet, constructed from galvanized sheet steel. The casing leakage rate shall be classified according to class II, VDI 3803/DIN 24 194 and the duct-sleeve connections shall be 30 mm flange type. The VAV units shall have a multi-leaf opposed blade damper with steel damper shaft rotating in self lubricating Nylon bearings. A centre averaging airflow sensor with at least 2 x 12 test points and amplified signal air flow sensor, type Flo-Cross® shall control the airflow with an accuracy not less than 2.5 %. The VAV unit shall be supplied with an additional sound attenuator made of galvanised sheet steel and internal isolation according to class 'O' fir regulation. The controller shall be I/A Series, LON® compatible, DDC controller type MNL-V2RVx or BACnet® compatible type MNB-V2. Controls must be factory fitted, wired and calibrated according to the following requirements.

Maximum air volume 1280 l/s
Minimum air volume 512 l/s
Unit size 400 x 400 mm
Max. pressure loss 38 Pa
Max. discharge sound index < NC35 (@250Pa Δp)
Max. radiated sound index < NC35 (@250Pa Δp)

Ordering example: type – model – handing =
NLODOOB – 0400 - 0400

Manufacturer: HC Barcol-Air

Installation Instructions:

The HC Barcol-Air VAV terminals shall be installed using at least two support brackets (DIN-rail or L-profile), with anti-vibration rubber under the terminal. Each of these brackets shall be fixed with two threaded rods to the ceiling slab above.

This installation method:

- 1 Shall prevent the body of the VAV terminal from high mechanical tension, which could damage the construction and performance of the terminal.
- 2 Shall prevent torsion on the VAV terminals, which could cause malfunction of the damper blades.
- 3 Provides some flexibility to the final location of the VAV terminals.
- 4 Use at least 1x diagonal straight duct length before the VAV inlet.

- 5 Additional manual volume control dampers (VCD's) before the inlet are not required / recommended!!
6. All connections shall be thermally isolated.
7. Pressure sensing tubes of FloCross airflow sensor shall not be "kinked" or otherwise obstructed by the external duct insulation.

Optional 4 x Mupro fixing hooks can be used (see drawing).

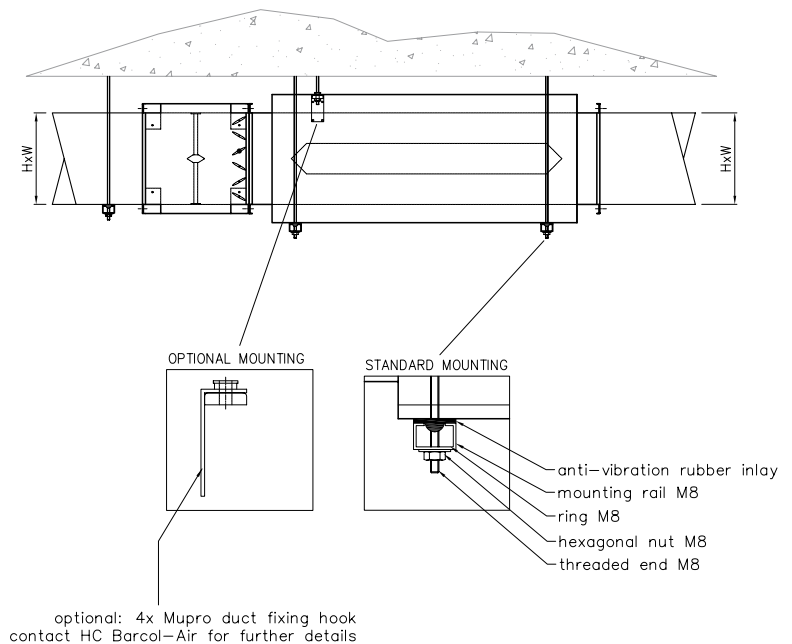

Rectangular VAV and CAV air volume control units

Model overview Single wall - type NK.....

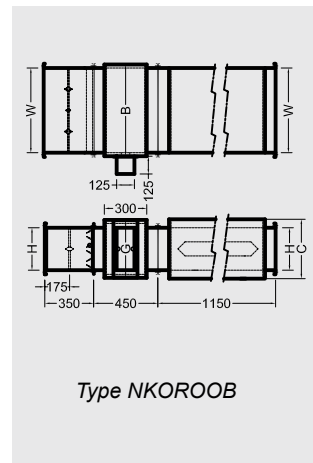
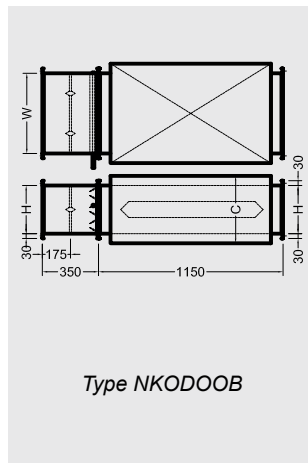
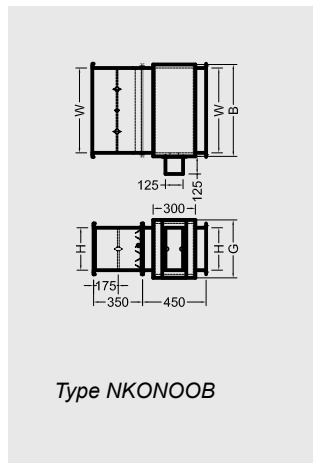
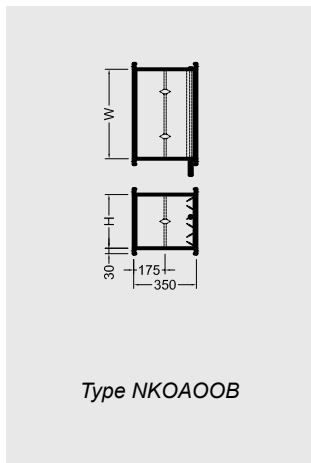
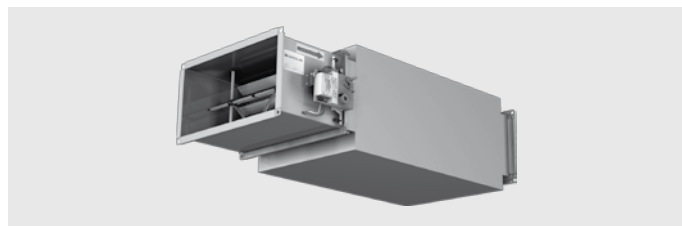
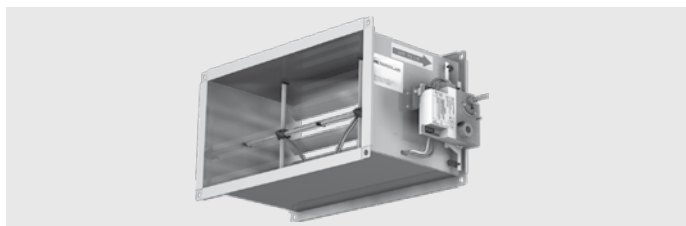

Dimensions NK.....

	B →			250	300	350	400	450	500	550	600	650	700	750
height C ↓	G ↓	H ↓	width W →	200	250	300	350	400	450	500	600	700	750	800
300	250	200		•	•	•	•	•	•	•	•	•	•	•
370	300	250			•	•	•	•	•	•	•	•	•	•
450	350	300				•	•	•	•	•	•	•	•	•
520	400	350					•	•	•	•	•	•	•	•
600	450	400						•	•	•	•	•	•	•
735	500	450							•	•	•	•	•	•
765	550	500								•	•	•	•	•
850	650	600									•	•	•	•

All dimensions in mm.

Kv values

Height (H)	Width (W)												
	200	250	300	350	400	450	500	600	700	750	800	900	1000
150	25	31	36	43	51	54	61	72					
200	34	44	51	60	68	78	88	103	122	132	137		
250		49	60	72	88	100	98	121	156	146	158	181	195
300			72	85	99	113	121	143	171	185	198	215	243
350				97	113	129	143	171	195	211	227	256	288
400					126	144	162	198	227	245	251	287	324
450						164	185	226	259	279	287	329	371
500							208	241	291	314	324	371	417
600								287	342	369	397	454	510

Flow = Kv x √ΔPfc
 ΔPfc = Flo-Cross signal
 If ΔPfc = 30 Pa and VAV size = 500 x 350
 Flow = 149 x √30 = 816 l/s

Rectangular VAV and CAV air volume control units

Model overview Double wall - type NL.....

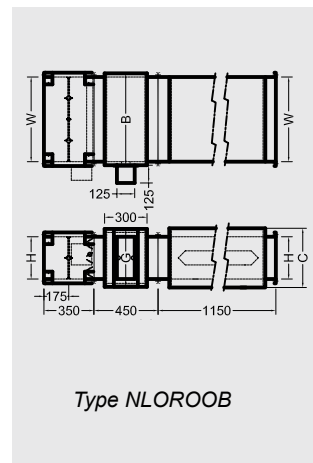
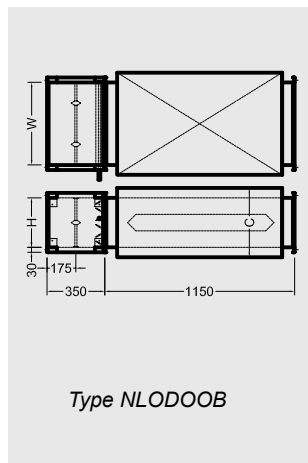
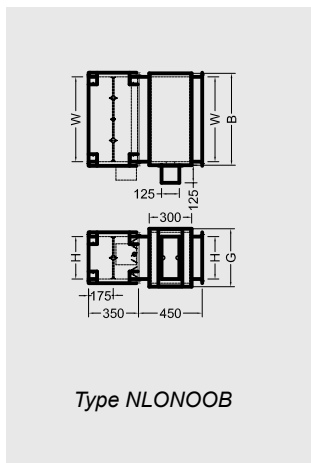
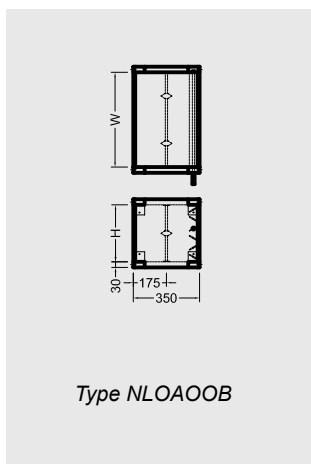
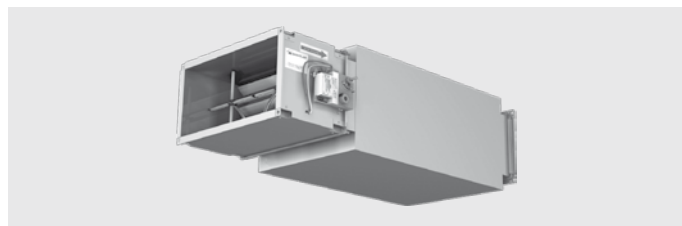

Dimensions NL.....

			B →	250	300	350	400	450	500	550	600	650	700	750
height C ↓	G ↓	H ↓	width W →	200	250	300	350	400	450	500	600	700	750	800
300	250	200		•	•	•	•	•	•	•	•	•	•	•
370	300	250			•	•	•	•	•	•	•	•	•	•
450	350	300				•	•	•	•	•	•	•	•	•
520	400	350					•	•	•	•	•	•	•	•
600	450	400						•	•	•	•	•	•	•
735	500	450							•	•	•	•	•	•
765	550	500								•	•	•	•	•
850	650	600									•	•	•	•

Other dimensions are available upon request

Kv values

Height (H)	Width (W)												
	200	250	300	350	400	450	500	600	700	750	800	900	1000
150	25	31	36	43	51	54	61	72					
200	34	44	51	60	68	78	88	103	122	132	137		
250		49	60	72	88	100	98	121	156	146	158	181	195
300			72	85	99	113	121	143	171	185	198	215	243
350				97	113	129	143	171	195	211	227	256	288
400					126	144	162	198	227	245	251	287	324
450						164	185	226	259	279	287	329	371
500							208	241	291	314	324	371	417
600								287	342	369	397	454	510

Flow = Kv x √ΔPfc
 ΔPfc = Flo-Cross signal
 If ΔPfc = 30 Pa and VAV size = 500 x 350
 Flow = 149 x √30 = 816 l/s

Rectangular VAV and CAV air volume control units

Type NK0A00B
NLOA00B



Sound data Δ p = 125 Pa

Model	Δ p = 125 Pa																															
	data referring to inlet spigot				min. Δ P _s	discharge sound									radiated sound single wall									radiated sound double wall								
						L _w in dB/Oct. (re 1pW)						Lp values			L _w in dB/Oct. (re 1pW)						Lp values			L _w in dB/Oct. (re 1pW)						Lp values		
	velocity	air volume			Pa	125 Hz	250 Hz	500 Hz	1000 Hz	2000 Hz	4000 Hz	dB(A)	NC	NR	125 Hz	250 Hz	500 Hz	1000 Hz	2000 Hz	4000 Hz	dB(A)	NC	NR	125 Hz	250 Hz	500 Hz	1000 Hz	2000 Hz	4000 Hz	dB(A)	NC	NR
m/s		l/s	CFM	m ³ /h		dB						dB						dB														
350 x 300 (DN 355)	2	210	445	756	1	47	48	43	27	30	22	21	--	--	33	32	26	-	-	-	--	--	--	29	28	22	-	-	-	--	--	--
	4	420	889	1512	6	57	60	56	45	44	37	33	28	30	43	44	39	31	28	29	23	--	--	39	40	35	27	24	23	--	--	--
	6	630	1334	2268	13	59	62	58	49	48	41	35	31	33	45	46	41	35	32	33	25	--	21	41	42	37	31	28	27	21	--	--
	8	840	1779	3024	23	58	61	55	47	47	41	33	29	31	44	45	38	33	31	33	23	--	--	40	41	34	29	27	27	--	--	--
	10	1050	2224	3780	35	60	60	54	47	49	42	34	29	31	46	44	37	33	33	34	23	--	--	42	40	33	29	29	28	--	--	--
350 x 350 (DN 400)	2	245	519	882	1	48	48	43	28	30	23	22	--	--	34	32	26	-	-	-	--	--	--	30	28	22	-	-	-	--	--	--
	4	490	1038	1764	6	58	61	57	46	45	38	34	29	31	44	45	40	32	29	30	23	--	--	40	41	36	28	25	24	--	--	--
	6	735	1556	2646	13	60	63	59	49	48	42	36	31	33	46	47	42	35	32	34	25	--	21	42	43	38	31	28	28	21	--	--
	8	980	2075	3528	23	58	61	56	48	47	41	34	30	32	44	45	39	34	31	33	24	--	--	40	41	35	30	27	27	--	--	--
	10	1225	2594	4410	35	61	61	55	48	50	43	34	29	31	47	45	38	34	34	35	24	--	--	43	41	34	30	30	29	20	--	--
400 x 400 (DN 450)	2	320	678	1152	1	49	50	44	29	31	24	23	--	--	35	34	27	-	-	-	--	--	--	31	30	23	-	-	-	--	--	--
	4	640	1355	2304	6	59	62	58	47	46	39	35	30	32	45	46	41	33	30	31	25	--	20	41	42	37	29	26	25	21	--	--
	6	960	2033	3456	13	61	64	60	51	50	43	37	33	35	47	48	43	37	34	35	27	--	23	43	44	39	33	30	29	23	--	--
	8	1280	2711	4608	23	60	63	57	49	49	43	35	31	33	46	47	40	35	33	35	25	--	21	42	43	36	31	29	29	21	--	--
	10	1600	3388	5760	35	62	62	56	49	51	44	36	31	33	48	46	39	35	35	36	25	--	21	44	42	35	31	31	30	21	--	--
500 x 400 (DN 500)	2	400	847	1440	1	49	50	45	30	32	25	23	--	--	35	34	28	-	-	-	--	--	--	31	30	24	-	-	-	--	--	--
	4	800	1694	2880	6	59	62	59	48	47	40	35	30	32	45	46	42	34	31	32	25	--	20	41	42	38	30	27	26	21	--	--
	6	1200	2541	4320	13	61	64	60	52	50	44	37	33	35	47	48	43	38	34	36	27	--	23	43	44	39	34	30	30	23	--	--
	8	1600	3388	5760	23	60	63	57	50	50	44	35	31	33	46	47	40	36	34	36	25	--	21	42	43	36	32	30	30	21	--	--
	10	2000	4235	7200	35	62	62	57	50	52	45	36	31	33	48	46	40	36	36	37	25	--	21	44	42	36	32	32	31	21	--	--
600 x 400 (DN 560)	2	480	1016	1728	1	49	50	45	31	33	26	23	--	--	35	34	28	-	17	17	--	--	--	31	30	24	-	-	-	--	--	--
	4	960	2033	3456	6	59	62	59	49	48	41	35	30	32	45	46	42	35	32	33	25	--	20	41	42	38	31	28	27	21	--	--
	6	1440	3049	5184	13	61	64	60	52	51	45	37	33	35	47	48	43	38	35	37	27	--	23	43	44	39	34	31	31	23	--	--
	8	1920	4066	6912	23	60	63	58	51	50	44	35	31	33	46	47	41	37	34	36	25	--	21	42	43	37	33	30	30	21	--	--
	10	2400	5082	8640	35	62	62	57	51	53	46	36	31	33	48	46	40	37	37	38	26	--	21	44	42	36	33	33	32	21	--	--
800 x 400 (DN 630)	2	640	1355	2304	1	49	50	46	32	34	27	23	--	--	35	34	29	18	18	19	--	--	--	31	30	25	-	-	-	--	--	--
	4	1280	2711	4608	6	59	62	59	50	49	42	35	30	32	45	46	42	36	33	34	25	--	20	41	42	38	32	29	28	21	--	--
	6	1920	4066	6912	13	61	64	61	54	53	46	37	33	35	47	48	44	40	37	38	27	--	23	43	44	40	36	33	32	23	--	--
	8	2560	5421	9216	23	60	63	58	52	52	46	35	31	33	46	47	41	38	36	38	25	--	21	42	43	37	34	32	32	21	--	--
	10	3200	6776	11520	35	62	62	57	52	54	47	36	31	33	48	46	40	38	38	39	26	--	21	44	42	36	34	34	33	22	--	--
900 x 450 (DN 710)	2	810	1715	2916	1	49	50	46	33	35	28	23	--	--	35	34	29	19	19	20	--	--	--	31	30	25	-	-	-	--	--	--
	4	1620	3431	5832	6	59	62	60	51	50	43	35	30	32	45	46	43	37	34	35	25	--	20	41	42	39	33	30	29	21	--	--
	6	2430	5146	8748	13	61	64	61	55	54	47	37	33	35	47	48	44	41	38	39	27	--	23	43	44	40	37	34	33	23	--	--
	8	3240	6861	11664	23	60	63	59	53	53	47	35	31	33	46	47	42	39	37	39	26	--	21	42	43	38	35	33	33	22	--	--
	10	4050	8576	14580	35	62	62	58	53	55	48	36	31	33	48	46	41	39	39	40	26	--	21	44	42	37	35	35	34	22	--	--

1. Sound data is determined in a reverberation room at an independent sound laboratory, according to ISO 3741 and ISO 5135 standards.
2. L_w in dB/Oct. (re 1pW) are sound power levels for discharge sound and case radiated sound. Figures less than 17 dB are indicated by "--".
3. The discharge sound pressure levels are determined with the assumptions as referred to in table 1 for downstream ductwork including a diffuser with insulated plenum box.
4. The radiated sound pressure levels are determined

- with the assumptions as referred to in table 1 for ceiling plenum and suspended ceiling absorption.
5. L_p values are including a room absorption of 10 dB/Oct.
6. dB(A), NC and NR index figures are sound pressure levels. Figures less than 20 are indicated by "--".
7. Δps is static pressure drop across VAV air volume control unit with damper fully open.
8. For non standard applications and/or selections, please contact our technical staff.

Table 1: Assumptions for additional attenuation.

Hz	125	250	500	1000	2000	4000
Discharge (dB)	5	10	20	30	30	25
Radiated (dB)	2	5	10	15	15	20

Table 2: Correction table for other unit sizes: $L_{pA}' = L_{pA(0.2)} + \Delta L_{pA}$

WxH (m ²)	0,03	0,04	0,05	0,06	0,07	0,08	0,10	0,12	0,14	0,16	0,18	0,20	0,25	0,30	0,40	0,50	0,60
Δ L _{pA} (dB)	-7	-6	-5	-4	-4	-3	-2	-1	-1	-1	0	0	0	1	1	1	2

Rectangular VAV and CAV air volume control units

Type **NK0A00B**
NL0A00B



Sound data $\Delta p = 250 \text{ Pa}$

Model	data referring to inlet spigot		min. Δp_s	$\Delta p = 250 \text{ Pa}$																												
				discharge sound									radiated sound single wall						radiated sound double wall													
	air volume			L_w in dB/Oct. (re 1pW)						Lp values			L_w in dB/Oct. (re 1pW)						Lp values			L_w in dB/Oct. (re 1pW)						Lp values				
				125 Hz	250 Hz	500 Hz	1000 Hz	2000 Hz	4000 Hz	dB(A)	NC	NR	125 Hz	250 Hz	500 Hz	1000 Hz	2000 Hz	4000 Hz	dB(A)	NC	NR	125 Hz	250 Hz	500 Hz	1000 Hz	2000 Hz	4000 Hz	dB(A)	NC	NR		
velocity				Pa	dB									dB									dB									
m/s	l/s	CFM	m ³ /h																													
350 x 300 (DN 355)	2	210	445	756	1	49	50	46	31	32	25	24	--	--	35	34	29	-	-	-	--	--	--	31	30	25	-	-	-	--	--	--
	4	420	889	1512	6	59	62	59	49	47	39	35	31	33	45	46	42	35	31	31	25	--	21	41	42	38	31	27	25	21	--	--
	6	630	1334	2268	13	66	70	68	60	56	49	43	40	41	52	54	51	46	40	41	33	27	29	48	50	47	42	36	35	29	23	25
	8	840	1779	3024	23	67	71	69	62	58	51	44	41	42	53	55	52	48	42	43	34	28	31	49	51	48	44	38	37	30	24	26
	10	1050	2224	3780	35	66	70	67	61	58	51	43	40	41	52	54	50	47	42	43	33	27	29	48	50	46	43	38	37	29	22	25
350 x 350 (DN 400)	2	245	519	882	1	50	51	47	32	33	25	24	--	21	36	35	30	18	17	17	--	--	--	32	31	26	-	-	-	--	--	--
	4	490	1038	1764	6	60	63	60	49	48	40	36	32	33	46	47	43	35	32	32	26	--	22	42	43	39	31	28	26	22	--	--
	6	735	1556	2646	13	67	71	69	61	57	50	44	41	42	53	55	52	47	41	42	34	28	30	49	51	48	43	37	36	30	23	26
	8	980	2075	3528	23	68	72	70	63	59	52	45	42	43	54	56	53	49	43	44	35	29	31	50	52	49	45	39	38	31	25	27
	10	1225	2594	4410	35	67	71	68	61	58	52	44	41	42	53	55	51	47	42	44	34	28	30	49	51	47	43	38	38	30	23	26
400 x 400 (DN 450)	2	320	678	1152	1	51	52	48	33	34	26	25	--	22	37	36	31	19	18	18	--	--	--	33	32	27	-	-	-	--	--	--
	4	640	1355	2304	6	61	64	61	50	49	41	37	33	35	47	48	44	36	33	33	27	--	23	43	44	40	32	29	27	23	--	--
	6	960	2033	3456	13	68	72	70	62	58	51	45	42	43	54	56	53	48	42	43	35	29	31	50	52	49	44	38	37	31	25	27
	8	1280	2711	4608	23	69	73	71	64	60	53	46	44	44	55	57	54	50	44	45	36	31	33	51	53	50	46	40	39	32	26	28
	10	1600	3388	5760	35	68	72	69	63	59	53	45	42	43	54	56	52	49	43	45	35	29	31	50	52	48	45	39	39	31	25	27
500 x 400 (DN 500)	2	400	847	1440	1	51	52	48	34	35	27	25	--	22	37	36	31	20	19	19	--	--	--	33	32	27	-	-	-	--	--	--
	4	800	1694	2880	6	61	64	61	51	50	42	37	33	35	47	48	44	37	34	34	27	--	23	43	44	40	33	30	28	23	--	--
	6	1200	2541	4320	13	68	72	71	63	59	52	45	42	43	54	56	54	49	43	44	36	29	31	50	52	50	45	39	38	31	25	27
	8	1600	3388	5760	23	69	73	71	65	61	54	46	44	44	55	57	54	51	45	46	36	31	33	51	53	50	47	41	40	32	26	28
	10	2000	4235	7200	35	68	72	69	64	60	54	45	42	43	54	56	52	50	44	46	35	29	31	50	52	48	46	40	40	31	25	27
600 x 400 (DN 560)	2	480	1016	1728	1	51	52	49	35	36	28	25	--	22	37	36	32	21	20	20	--	--	--	33	32	28	-	-	-	--	--	--
	4	960	2033	3456	6	61	64	62	52	50	43	37	33	35	47	48	45	38	34	35	27	--	23	43	44	41	34	30	29	23	--	--
	6	1440	3049	5184	13	68	72	71	64	60	53	45	42	43	54	56	54	50	44	45	36	29	31	50	52	50	46	40	39	32	25	27
	8	1920	4066	6912	23	69	73	71	66	62	55	46	44	44	55	57	54	52	46	47	37	31	33	51	53	50	48	42	41	33	26	28
	10	2400	5082	8640	35	68	72	69	64	61	55	45	42	43	54	56	52	50	45	47	35	29	31	50	52	48	46	41	41	31	25	27
800 x 400 (DN 630)	2	640	1355	2304	1	51	52	49	36	37	29	26	--	22	37	36	32	22	21	21	--	--	--	33	32	28	18	17	-	--	--	--
	4	1280	2711	4608	6	61	64	62	53	52	44	37	33	35	47	48	45	39	36	36	28	--	23	43	44	41	35	32	30	23	--	--
	6	1920	4066	6912	13	68	72	71	65	61	54	45	42	43	54	56	54	51	45	46	36	29	31	50	52	50	47	41	42	32	25	27
	8	2560	5421	9216	23	69	73	72	67	63	56	46	44	44	55	57	55	53	47	48	37	31	33	51	53	51	49	43	40	33	26	28
	10	3200	6776	11520	35	68	72	70	66	62	56	45	42	43	54	56	53	52	46	48	36	29	31	50	52	49	48	42	42	32	25	27
900 x 450 (DN 710)	2	810	1715	2916	1	51	52	49	37	38	30	26	--	22	37	36	32	23	22	22	--	--	--	33	32	28	19	18	-	--	--	--
	4	1620	3431	5832	6	61	64	63	54	53	45	37	33	35	47	48	46	40	37	37	28	--	23	43	44	42	36	33	31	24	--	--
	6	2430	5146	8748	13	68	72	72	66	62	55	45	42	43	54	56	55	52	46	47	36	29	31	50	52	51	48	42	41	32	25	27
	8	3240	6861	11664	23	69	73	72	68	64	57	46	44	44	55	57	55	54	48	49	37	31	33	51	53	51	50	44	43	33	26	28
	10	4050	8576	14580	35	68	72	70	67	64	57	45	42	43	54	56	53	53	48	49	36	29	31	50	52	49	49	44	43	32	25	27

1. Sound data is determined in a reverberation room at an independent sound laboratory, according to ISO 3741 and ISO 5135 standards.
2. L_w in dB/Oct. (re 1pW) are sound power levels for discharge sound and case radiated sound. Figures less than 17 dB are indicated by "--".
3. The discharge sound pressure levels are determined with the assumptions as referred to in table 1 for downstream ductwork including a diffuser with insulated plenum box.
4. The radiated sound pressure levels are determined

- with the assumptions as referred to in table 1 for ceiling plenum and suspended ceiling absorption.
5. Lp values are including a room absorption of 10 dB/Oct.
 6. dB(A), NC and NR index figures are sound pressure levels. Figures less than 20 are indicated by "--".
 7. Δp_s is static pressure drop across VAV air volume control unit with damper fully open.
 8. For non standard applications and/or selections, please contact our technical staff.

Table 1: Assumptions for additional attenuation.

Hz	125	250	500	1000	2000	4000
Discharge (dB)	5	10	20	30	30	25
Radiated (dB)	2	5	10	15	15	20

Table 2: Correction table for other unit sizes: $L_{pA}' = L_{pA(0,2)} + \Delta L_{pA}$

WxH (m ²)	0,03	0,04	0,05	0,06	0,07	0,08	0,10	0,12	0,14	0,16	0,18	0,20	0,25	0,30	0,40	0,50	0,60
ΔL_{pA} (dB)	-7	-6	-5	-4	-4	-3	-2	-1	-1	-1	0	0	0	1	1	1	2

Rectangular VAV and CAV air volume control units

Type NKODOOB
NLODOOB

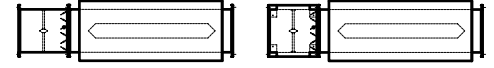

Sound data $\Delta p = 125 \text{ Pa}$

Model	$\Delta p = 125 \text{ Pa}$																															
	data referring to inlet spigot				min. Δp_s	discharge sound									radiated sound single wall						radiated sound double wall											
	velocity			air volume		L_w in dB/Oct. (re 1pW)						Lp values			L_w in dB/Oct. (re 1pW)						Lp values			L_w in dB/Oct. (re 1pW)						Lp values		
	m/s	l/s	CFM	m ³ /h	Pa	125 Hz	250 Hz	500 Hz	1000 Hz	2000 Hz	4000 Hz	dB(A)	NC	NR	125 Hz	250 Hz	500 Hz	1000 Hz	2000 Hz	4000 Hz	dB(A)	NC	NR	125 Hz	250 Hz	500 Hz	1000 Hz	2000 Hz	4000 Hz	dB(A)	NC	NR
350 x 300 (DN 355)	2	210	445	756	8	43	38	24	-	-	-	-	-	33	32	26	-	-	-	-	-	-	29	28	22	-	-	-	-	-	-	
	4	420	889	1512	31	53	50	37	26	25	19	25	-	43	44	39	31	28	29	23	-	-	39	40	35	27	24	23	-	-	-	
	6	630	1334	2268	69	53	50	36	26	26	21	25	-	43	44	38	32	29	31	22	-	-	39	40	34	28	25	25	-	-	-	
	8	840	1779	3024	123	X	X	X	X	X	X	X	X	X	X	X	X	X	X	X	X	X	X	X	X	X	X	X	X	X	X	X
	10	1050	2224	3780	192	X	X	X	X	X	X	X	X	X	X	X	X	X	X	X	X	X	X	X	X	X	X	X	X	X	X	X
350 x 350 (DN 400)	2	245	519	882	8	43	39	27	-	-	-	-	-	33	32	26	-	-	-	-	-	-	29	28	22	-	-	-	-	-	-	
	4	490	1038	1764	33	54	51	40	28	27	21	26	-	44	45	40	32	29	30	23	-	-	40	41	36	28	25	24	-	-	-	
	6	735	1556	2646	73	54	51	39	29	28	23	25	-	44	45	39	32	30	31	23	-	-	40	41	35	28	26	25	-	-	-	
	8	980	2075	3528	129	X	X	X	X	X	X	X	X	X	X	X	X	X	X	X	X	X	X	X	X	X	X	X	X	X	X	X
	10	1225	2594	4410	202	X	X	X	X	X	X	X	X	X	X	X	X	X	X	X	X	X	X	X	X	X	X	X	X	X	X	X
400 x 400 (DN 450)	2	320	678	1152	8	45	41	29	-	-	-	-	-	35	34	27	-	-	-	-	-	-	31	30	23	-	-	-	-	-	-	
	4	640	1355	2304	32	55	53	42	31	30	24	27	-	45	46	41	33	30	31	24	-	-	41	42	37	29	26	25	20	-	-	
	6	960	2033	3456	72	55	53	41	31	31	25	27	-	45	46	40	33	31	32	24	-	-	41	42	36	29	27	26	20	-	-	
	8	1280	2711	4608	127	X	X	X	X	X	X	X	X	X	X	X	X	X	X	X	X	X	X	X	X	X	X	X	X	X	X	X
	10	1600	3388	5760	198	X	X	X	X	X	X	X	X	X	X	X	X	X	X	X	X	X	X	X	X	X	X	X	X	X	X	X
500 x 400 (DN 500)	2	400	847	1440	8	45	41	29	-	18	-	-	-	35	34	28	-	-	-	-	-	-	31	30	24	-	-	-	-	-	-	
	4	800	1694	2880	32	55	53	42	32	31	25	27	-	45	46	41	34	31	32	25	-	-	41	42	37	30	27	26	21	-	-	
	6	1200	2541	4320	71	55	53	41	32	32	26	27	-	45	46	40	34	32	33	24	-	-	41	42	36	30	28	27	20	-	-	
	8	1600	3388	5760	126	X	X	X	X	X	X	X	X	X	X	X	X	X	X	X	X	X	X	X	X	X	X	X	X	X	X	X
	10	2000	4235	7200	196	X	X	X	X	X	X	X	X	X	X	X	X	X	X	X	X	X	X	X	X	X	X	X	X	X	X	X
600 x 400 (DN 560)	2	480	1016	1728	8	45	41	29	17	18	-	-	-	35	34	28	-	17	17	-	-	-	31	30	24	-	-	-	-	-	-	
	4	960	2033	3456	31	55	53	43	33	32	26	27	-	45	46	42	35	32	33	25	-	-	41	42	38	31	28	27	21	-	-	
	6	1440	3049	5184	70	55	53	42	33	33	27	27	-	45	46	41	35	33	34	24	-	-	41	42	37	31	29	28	20	-	-	
	8	1920	4066	6912	125	X	X	X	X	X	X	X	X	X	X	X	X	X	X	X	X	X	X	X	X	X	X	X	X	X	X	X
	10	2400	5082	8640	195	X	X	X	X	X	X	X	X	X	X	X	X	X	X	X	X	X	X	X	X	X	X	X	X	X	X	X
800 x 400 (DN 630)	2	640	1355	2304	8	45	41	30	18	19	-	-	-	35	34	29	18	18	19	-	-	-	31	30	25	-	-	-	-	-	-	
	4	1280	2711	4608	31	55	53	43	34	33	27	27	-	45	46	42	36	33	34	25	-	-	41	42	38	32	29	28	21	-	-	
	6	1920	4066	6912	70	55	53	42	34	34	29	27	-	45	46	41	36	34	35	25	-	-	41	42	37	32	30	29	21	-	-	
	8	2560	5421	9216	124	X	X	X	X	X	X	X	X	X	X	X	X	X	X	X	X	X	X	X	X	X	X	X	X	X	X	X
	10	3200	6776	11520	193	X	X	X	X	X	X	X	X	X	X	X	X	X	X	X	X	X	X	X	X	X	X	X	X	X	X	X
900 x 450 (DN 710)	2	810	1715	2916	9	45	41	30	19	20	-	-	-	35	34	29	19	19	20	-	-	-	31	30	25	-	-	-	-	-	-	
	4	1620	3431	5832	36	55	53	44	35	34	28	27	-	45	46	43	37	34	35	25	-	-	41	42	39	33	30	29	21	-	-	
	6	2430	5146	8748	80	55	53	42	35	35	30	27	-	45	46	41	37	35	37	25	-	-	41	42	37	33	31	31	21	-	-	
	8	3240	6861	11664	142	X	X	X	X	X	X	X	X	X	X	X	X	X	X	X	X	X	X	X	X	X	X	X	X	X	X	X
	10	4050	8576	14580	221	X	X	X	X	X	X	X	X	X	X	X	X	X	X	X	X	X	X	X	X	X	X	X	X	X	X	X

- Sound data is determined in a reverberation room at an independent sound laboratory, according to ISO 3741 and ISO 5135 standards.
- L_w in dB/Oct. (re 1pW) are sound power levels for discharge sound and case radiated sound. Figures less than 17 dB are indicated by "-".
- The discharge sound pressure levels are determined with the assumptions as referred to in table 1 for downstream ductwork including a diffuser with insulated plenum box.
- The radiated sound pressure levels are determined

- with the assumptions as referred to in table 1 for ceiling plenum and suspended ceiling absorption.
- Lp values are including a room absorption of 10 dB/Oct.
- dB(A), NC and NR index figures are sound pressure levels. Figures less than 20 are indicated by "-".
- Δp_s is static pressure drop across VAV air volume control unit with damper fully open.
- For non standard applications and/or selections, please contact our technical staff.

Table 1: Assumptions for additional attenuation.

Hz	125	250	500	1000	2000	4000
Discharge (dB)	5	10	20	30	30	25
Radiated (dB)	2	5	10	15	15	20

Table 2: Correction table for other unit sizes: $L_{pA}' = L_{pA(0,2)} + \Delta L_{pA}$

WxH (m ²)	0,03	0,04	0,05	0,06	0,07	0,08	0,10	0,12	0,14	0,16	0,18	0,20	0,25	0,30	0,40	0,50	0,60
ΔL_{pA} (dB)	-7	-6	-5	-4	-4	-3	-2	-1	-1	-1	0	0	0	1	1	1	2



HC Barcol-Air

P.O. Box 283, 1440 AG Purmerend, the Netherlands

T +31 (0)299 689 300 | F +31 (0)299 436 932

info@barcol-air.nl | www.barcol-air.nl